

# Installation and Maintenance Instructions

---

## Saf-T Vent<sup>®</sup> SC/SC 316

### Double Wall One Inch Air Space Special Gas Vent

---

For Venting Residential and Light Commercial Appliances  
Category I,II,III,IV Appliances  
Certain Approved Direct Vent and/or Sealed Combustion Appliances  
For Use on Positive, Neutral, and Negative Pressures up to 8" W.C.

***IMPORTANT: Do not install this product until you have read and fully understand these installation instructions. Failure to comply with these instructions will result in an improper installation and will void any stated warranty.***

- Examine all components for possible shipping damage prior to installation.
- Proper joint assembly is essential for a safe installation.  
Follow these instructions exactly as written.  
Check severeness of joints upon completion of assembly.
- This venting system must be free to expand and contract.  
This venting system must be supported in accordance with these instructions.
- Check for unrestricted vent movement through the walls, ceilings, and roof penetrations.
- Different Manufacturers Have Different Joint Systems and Seals.  
Do Not Mix Pipe, Fittings, or Joining Methods from Different Manufacturers.
- Seal weather exposed joints of the outer jacket with foil tape or an exterior grade silicone sealant.



Tested and Listed to  
UL 1738/ULC S636  
by Underwriters Laboratories, Inc

**heatfab<sup>®</sup>**

5030 Corporate Exchange Blvd  
Grand Rapids, MI 49512  
Call 800 772-0739  
Fax 800 972-1421  
[www.heatfab.com](http://www.heatfab.com)

---

---

## TABLE OF CONTENTS

<b>CATEGORY</b>	<b>PAGE</b>
Introduction	3
Pre-Installation Considerations	3
General Installation Considerations	3
Clearances to Combustibles	4
Horizontal Installations	5
Vertical Installations	6
Joint Assembly Instructions	7
Cut to Length	8
Adapting to Saf-T Vent EZ Seal / EZ Seal	9
Air Intake Connection	10
Appliance Connection	10
Condensate Drains	11
Horizontal Supports	12
Vertical Supports	13
Fire Stop / Wall Thimble / Support	14
Horizontal Terminations	14
Tall Cone Flashing	15
Vertical Terminations	15
Maintenance	16
Warranty	16

---

## Introduction:

Saf-T Vent SC/SC 316 is an advanced concentric vent system designed for zero clearance installation in residential and light commercial applications. Saf-T Vent SC inner wall is constructed from super-ferritic AL 29-4C® stainless steel. Saf-T Vent SC 316 inner wall is constructed from 316L stainless steel. The outer wall is constructed from 409 stainless steel, providing durability and a lasting finish.

The double-wall construction of Saf-T Vent SC/SC 316 allows the system to be fully enclosed by combustible materials at zero or 1-inch clearance depending on orientation and flue gas temperature. Saf-T Vent SC/SC 316 is UL and CUL Listed to UL 1738 (File MH16161). It may be used on negative, neutral, and positive pressure systems up to 8 inches w.c. Saf-T Vent SC and SC 316 components are compatible and may be combined for installations.

**As a Special Gas Vent system:** Saf-T Vent is approved for use on ANSI Category I, II, III, and IV Gas-Burning Appliances and certain Direct Vent appliances. Saf-T Vent SC is appropriate for use on appliances that specify an AL 29-4C venting system.

**As a Sealed Combustion system:** The unique concentric design of Saf-T Vent SC/SC 316 also allows it to function as a pipe-in-a-pipe vent. Products of combustion are exhausted out through the inner wall while combustion air is drawn in through the outer wall. An appliance can be direct-vented with only a single penetration through the building structure. **This application must be approved by the Appliance Manufacturer**

**Note:** Saf-T Vent SC/SC 316 includes an integral seal and does not require sealant. However, sealant may be necessary when connecting Saf-T Vent SC/SC 316 components directly to certain appliance flue collars and to the gasket-less Saf-T Vent GC/GC 316 and Saf-T Vent CI/CI 316 vent systems.

For applications up to 550°F/288°C, approved sealants include GE RTV 106 and Dow Corning 736.

For applications up to 300°F/149°C, approved sealants include GE RTV 106 and Dow Corning 732.

## Pre-Installation Considerations:

- Proper planning prior to installation is essential as to avoid possible contact with concealed plumbing or electrical wiring inside walls, floors or ceilings as well as maintaining proper clearances. Be sure to plan a sufficient number of supports for the entire system that will maintain the required straight-line pitch and hold the system in place. A continuous straight-line pitch of at least 1/4 inch (2 degrees) to the foot on horizontal runs must be maintained in order to properly rid the system of the corrosive condensate.

## General Installation Requirements:

- The appliance manufacturer's instructions take precedence over this document.
- Failure to conform to any of these requirements may violate local, state, national or international codes as well as create conditions which may cause catastrophic property damage or personal injury. Failure to conform to any of these requirements will also void any warranties, stated or implied.
- Saf-T Vent SC/SC 316 vent sections, or other Saf-T Vent products, *must* be used throughout the entire length of the system. Alternatives such as galvanized pipe, PVC, nonmetallic pipe, prefabricated chimney, field-fabricated vents or Type B vent sections must not be used. Do not mix pipes, fittings, or joining methods from different manufacturers.
- If called for by the appliance manufacturer's instructions, a drain fitting must be located as close as possible to the appliance flue outlet.
- More than one appliance may not be interconnected to any part of the venting system. All connected appliances must be all natural draft or all forced draft.
- Any penetrations of ceilings, floors, or walls must be properly fire-stopped.
- Whenever gas-burning equipment is installed in the same space where halogenated substances may exist (refrigerants, solvents, bleaches, salts, etc.), clean outside air must be utilized for combustion.
- The vent system shall not be routed into, through or within any other actively used vent or chimney.
- Seal weather exposed joints of the outer jacket with foil tape or an exterior grade silicone sealant.

## Clearances to Combustibles:

DIAMETER	CLEARANCE TO COMBUSTIBLE MATERIAL	MAXIMUM FLUE GAS TEMP. (°F)	ORIENTATION	ENCLOSURE
3" - 4"	0"	550	Vertical, No Offsets	Fully enclosed by combustible material on all sides
3" - 4"	0"	330	Horizontal, Vertical With Offsets	Fully enclosed by combustible material on all sides
3" - 4"	1"	400	Horizontal, Vertical With Offsets	Fully enclosed by combustible material on all sides
3" - 4"	0"	400	Horizontal, Vertical With Offsets	Unenclosed, at least 1 side open, combustible material on a maximum of 3 sides
	1"	550		
3" - 4"	0"	550	Any	Noncombustible material

- The allowed clearances may differ by the appliance manufacturer. The appliance manufacturer's instructions and applicable local codes take precedence over this document.
- Combustible Material is any material made of or surfaced with wood, compressed paper, plant fibers, or other materials that are capable of being ignited or burned. Such material shall be considered combustible even though it is flame-proofed, fire-retardant, or plastered. (Source: NFPA54/ANSI Z223. 1-1999.)
- Non-Combustible Material is any material that is not capable of being ignited and burned, such material consisting entirely of, or a combination of, steel, iron, brick, tile, concrete, slate, asbestos, glass, and plaster. (Source: NFPA54/ANSI Z223. 1-1999.)
- For a venting system that extends through any zone above that on which the connected appliance is located (except for one and two family dwellings), the vent system shall be enclosed with an enclosure having a fire resistance rating equal to or greater than that of the floor or roof assemblies through which it passes.
- Design any enclosure to permit inspection of the system.
- Do not place any type of insulation in any required clearance spaces surrounding the vent system.

---

## Horizontal Installation Requirements:

1. The horizontal vent connector must slope **upward** toward the termination at least 1/4 inch per foot and be installed so that all condensate runs back toward the appliance and is not retained in any part of the venting system. **EXCEPTION:** If the system is connected to positive pressure (Category III or IV) appliances only, terminates with a horizontal termination, and has no provision for draining condensation and/or rain water; then the vent must pitch **downward** toward the termination. This pitch must also be at least 1/4 inch per foot (2 degrees).

2. **Seal weather exposed joints of the outer jacket with foil tape or an exterior grade silicone sealant.**

3. The vent system must terminate with one of the Saf-T Vent terminations or other terminations as specified or provided by the appliance manufacturer, or approved mechanical vent devices.

4 The Termination Location:

(a) The vent must terminate at least 3 feet above any forced air inlet located within 10 feet.

(b) The vent must terminate at least 4 feet below, 4 feet horizontally from or 1 foot above AND 2 feet horizontally from any door, window or gravity air inlet into any building. Exception: Direct Vent appliances may be listed for alternate spacing.

(c) The vent termination must be at least 12 inches above grade or, in geographical areas where snow accumulates, at least 12 inches above the anticipated snow line.

(d) Through-the-wall vents for Category II and IV appliances and noncategorized condensing appliances must not terminate over a public walkway or an area where condensate or vapors could create a nuisance or hazard or could be detrimental to the operation of regulators, relief valves or other equipment. In colder climates where ice buildup is likely to occur, Heat-fab, Inc. will **NOT** be held liable for any personal injury or property damage due to any formation of ice.

(e) The vent termination must be at least 8 feet horizontally from any combustion air intake, located above it.

5. Horizontal supports are required for every 6 feet of horizontal run and after every transition from vertical to horizontal.

6. The total continuous distance of the vent system from the appliance flue collar to the termination must not exceed that specified in the appliance manufacturer's installation instructions. When venting natural draft appliances the termination must be at least 5 feet above the topmost draft hood, otherwise a Listed mechanical draft inducing device may be required.

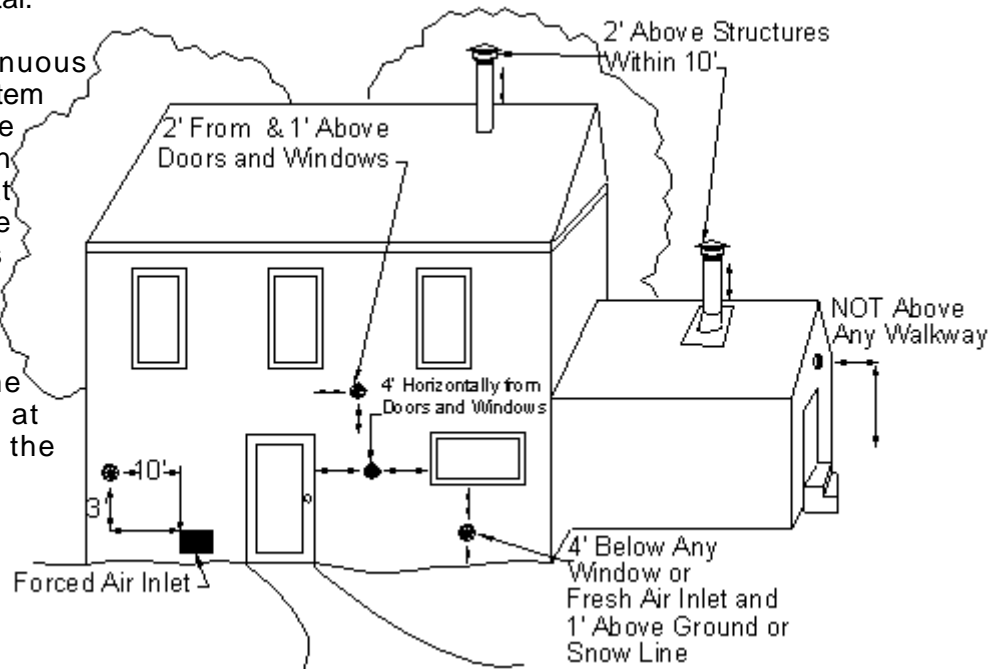

---

## Vertical Installation Requirements:

1. **Seal weather exposed joints of the outer jacket with foil tape or an exterior grade silicone sealant.**

2. The vent system must terminate at least 3 feet above the roof line and at least 2 feet higher than any portion of the building within 10 feet.

3. When terminated at a height of more than 6 feet the stack must be supported by a support bracing. The vent should be supported every 10 feet.

4. The vent system must terminate with one of the Saf-T Vent Terminations; exceptions:

(a) Category I or II appliances (natural draft) must use a Saf-T Vent Rain Cap.

(b) Vent systems without provisions for draining rain water must use a Saf-T Vent Rain Cap.

(c) Terminations or approved mechanical vent devices specified or provided by the appliance manufacturer are permitted.

5. The total continuous distance of the vent system from the appliance flue collar to the termination shall not exceed that specified in the appliance manufacturer's installation instructions. When venting natural draft appliances the termination must be at least 5 feet above the topmost draft hood. Otherwise a Listed mechanical draft inducing device is required.

6. In cold climates do not install a condensate drain on the exterior of the building. Doing so may result in dangerous icy conditions on surfaces near the drain and may cause damage to the vent system and/or the building exterior. Heat-fab, Inc. will **NOT** be held liable for any personal injury or property damage due to any formation of ice.

7. Install supports every 10 feet vertically along the vent pipe route. Vertical supports are required after every transition to vertical and are required after every offset elbow. When the vent is free standing and penetrates a roof/ceiling another means of support must be used at a second location. Refer to the Vertical Supports section in this manual.

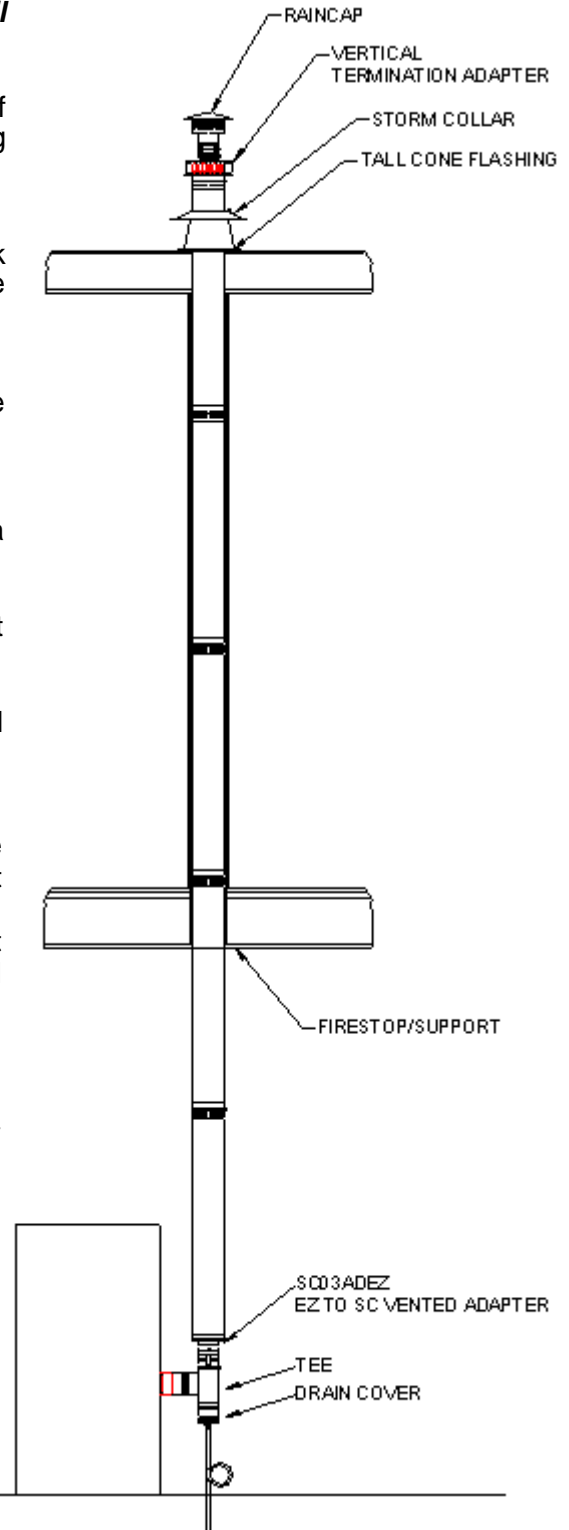

**Typical Vertical Installation**

---

## Joint Assembly Instructions:

1. Before joining the sections or fittings together, use an alcohol pad to wipe the joint area of both ends of the inner pipe. This will remove any foreign matter which may affect the integrity of the seal. Install the system with the female ends (ends with the red seal) pointing away from the appliance. (Unless specified differently by the appliance manufacturer.)

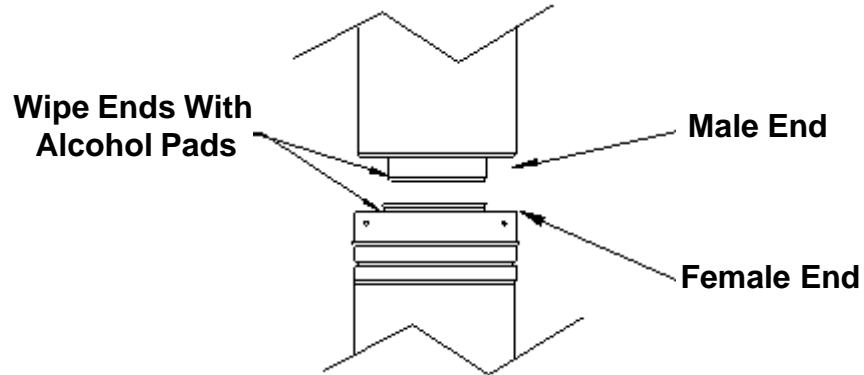

2. Insert the male end of the inner pipe into the female end of the previous section. In extremely dry conditions it may be helpful to moisten the seal with clean water prior to assembly. Push firmly until the outer jacket has made contact with the snap ring located inside the female end of the previous section. When fully assembled the outer female end will overlap the male end 1".

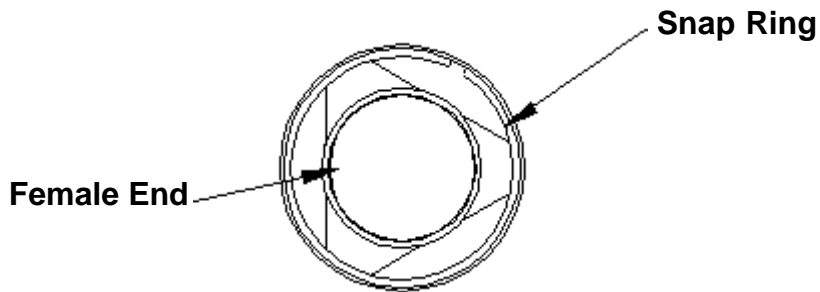

3. Use the self-tapping screws provided to connect the outer vents. No pre-drilling is required. **CAUTION:** Do not overtighten. If using a variable torque drill, **use a low torque setting to install screws**, as not to strip out the holes. If a hole becomes stripped due to overtightening, a larger diameter screw (1/2" long max.) or short pop rivet can be used.

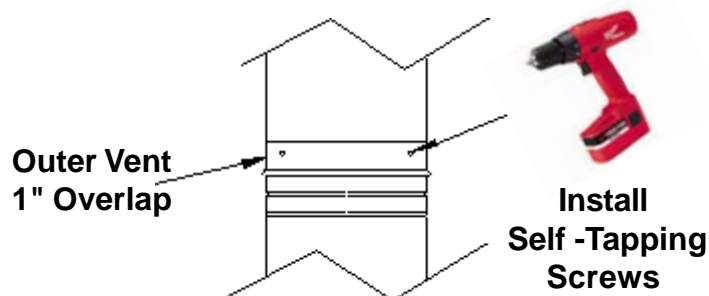

---

## Straight Sections Cut To Length:

If a custom length of SC/SC 316 is necessary, a standard vent section can be cut.

1. Measure the distance of the length needed, taking the measurement from the end of one of the outer jackets to the beginning of the other outer jacket on the section to connect to, (A to B on diagram).
2. Select a section that is longer than the required length.
3. It will be necessary to disassemble the vent prior to cutting.

Stand the section on end with the holes up. Find the end of snap ring and pry it out of its groove, being careful not to damage the ends of the vent pipes. Pull up on end of the snap ring and pull it out from the end of the pipe. It may want to spiral out as it is removed. After the snap ring is removed, the inner vent pipe can be separated from the outer jacket.

4. Add **2"** to the distance measured previously for the cut length of the outer jacket. Mark a cut line on the outer jacket on the male end (the end without holes in it).

An effective way of marking is to run a length of tape around the section, assuring a square cut.

5. Add **3"** to the distance measured previously for the cut length of the inner vent pipe. Mark a cut line on the inner vent on the male end (the end without the red seal).

***The inner pipe is always cut 1" longer than the outer pipe***

6. **WEAR GLOVES**, as cut ends are very sharp. Cut the pipes with an abrasive cutoff saw, plasma cutter, or compound snips. If using snips, start the cut at the male end and follow a spiral path around the pipe until the cutoff mark is reached. File off any burrs or rough edges that develop in the cutting process, and clean off any dust or grit. If the cutting process distorts the roundness of the pipes, carefully use your thumbs to re-round the ends.

7. Reassemble the inner vent into the outer jacket and reinstall the snap ring into the groove. Push the inner vent into the outer jacket until the triangle on the inner vent is seated firmly against the bead on outer jacket. Start one end of the snap ring into the groove of the outer pipe. Slowly turn and feed the snap ring into the groove in a spiral motion, and continue around the pipe until the snap ring is fully inserted. Ensure that the triangle on the inner vent is all the way down against the bead of the outer jacket by pushing in firmly. Also ensure that the snap ring is completely in the groove all the way around outer jacket.

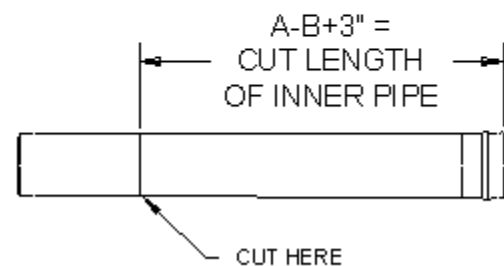
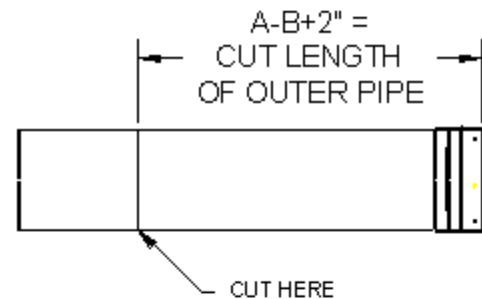
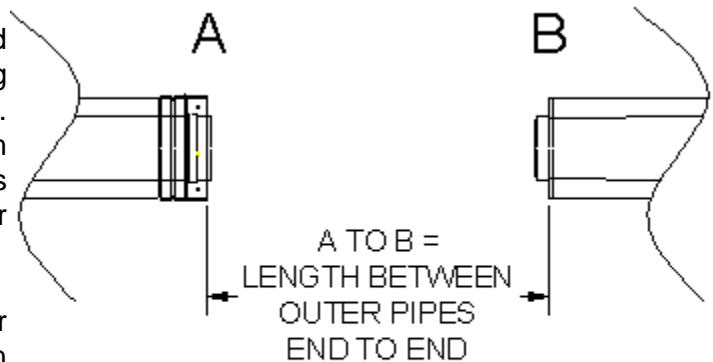



---

## Adapting to EZ Seal/EZ 316:

Saf-T Vent SC/SC 316 is compatible with other Saf-T Vent products. An adapter (SC\_ \_ADEZ) is used to connect Saf-T Vent SC/SC 316 to Saf-T Vent EZ/EZ 316 Seal or Saf-T Vent appliance adapters and flue collars.

- Insert the male end of the SC adapter into the female end of the EZ/EZ 316 Seal vent section and complete the ring and tab connection (refer to EZ Seal/EZ 316 instructions).
- Begin the Saf-T Vent SC/SC 316 system by inserting the male end of the SC/SC 316 section into the female end of the adapter. Secure the joint as described elsewhere in this manual.
- **WARNING:** The openings in the vent adapter must be kept uncovered and unobstructed to prevent the risk of fire.

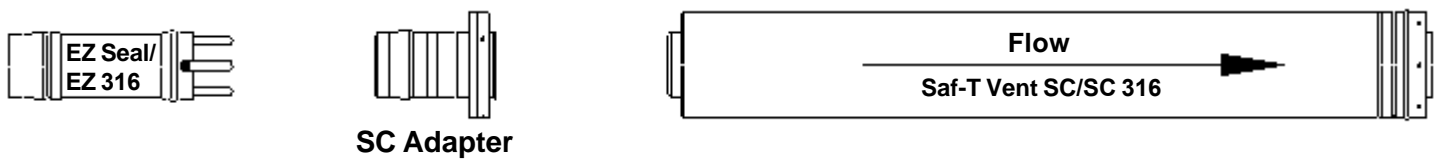

## Typical Saf-T Vent SC Installation:

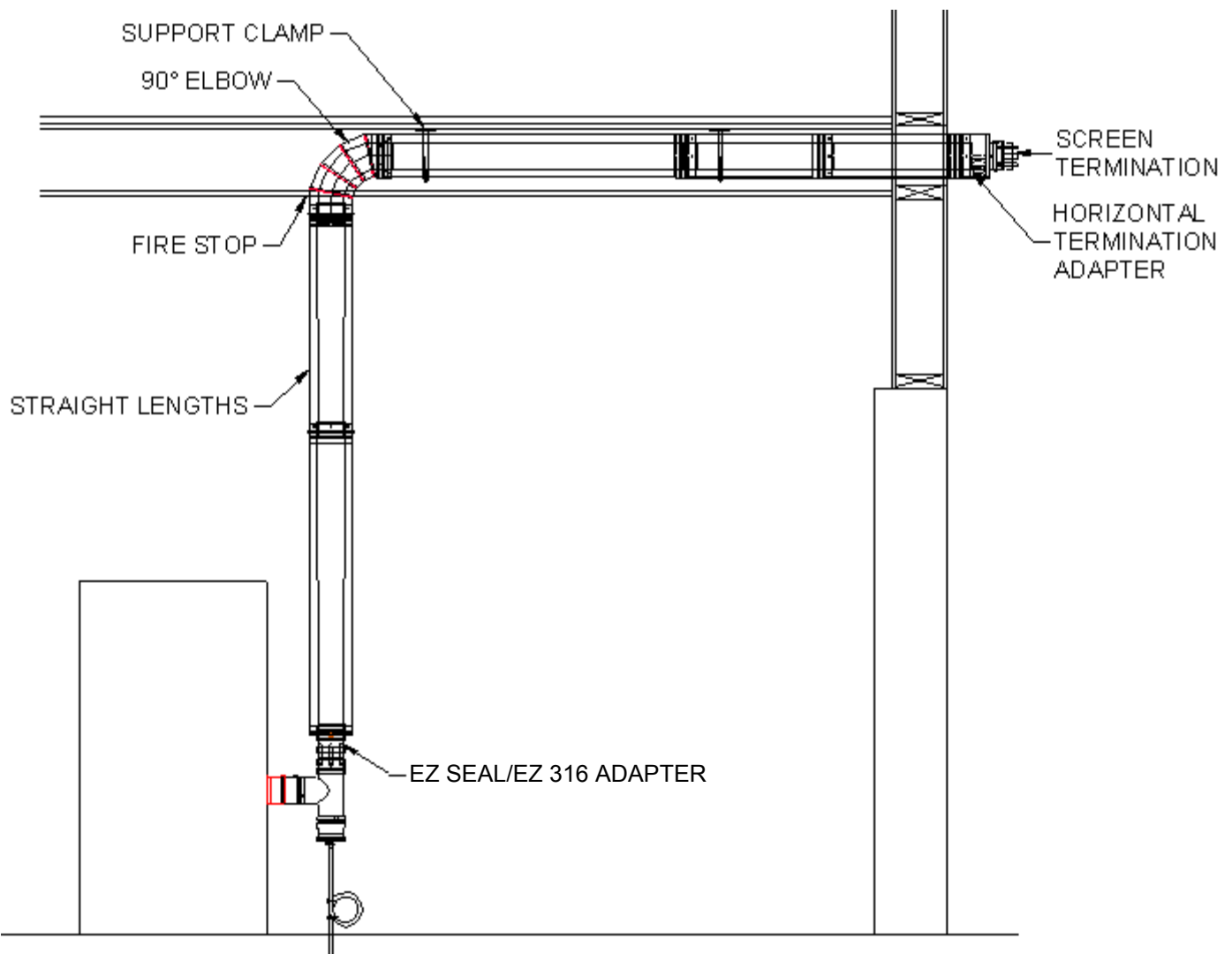

## Air Intake Connections for Direct Vent and Sealed Combustion Appliances\*:

- **WARNING:** This application must be approved by the Appliance Manufacturer.

The Air Intake Tee may be used on approved direct vent and sealed combustion appliances that have separate (non-concentric) air intake and flue exhaust collars. The male end of the tee connects to EZ Seal appliance adapters and the tee takeoff /snout connects to the appliance air intake.

- Insert the male end of the Air Intake Tee into the female end of the EZ Seal/EZ 316 vent section or appliance adapter and complete the ring and tab connection.
- Insert the male end of the next SC/SC 316 section into the female end of the Air Intake Tee and secure as described elsewhere in this manual.
- Connect the tee takeoff to the appliance combustion air inlet using appropriate hose or pipe.
- **WARNING:** If not attached to an appliance's air intake, the opening in the Air Intake Tee must be kept uncovered and unobstructed to prevent the risk of fire.

\* Direct Vent Appliances are constructed and installed so that all air for combustion is supplied directly from the outside atmosphere. The passage for the combustion air is allowed a small amount of leakage in the building envelope. No special installation considerations are required to use Saf-T Vent SC/SC 316 on Direct Vent appliances unless specified by the appliance manufacturer. Sealed Combustion appliances are similar to Direct Vent except the combustion air passage must be sealed to prevent leakage within the building envelope. When Saf-T Vent SC/SC 316 is used on approved Sealed Combustion appliances the joints of the outer jacket must be sealed with a foil tape (example: 3M 425), or approved silicone sealant (example: Dow Corning 732).

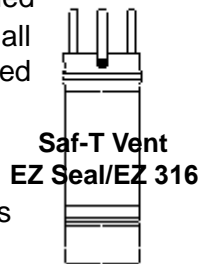
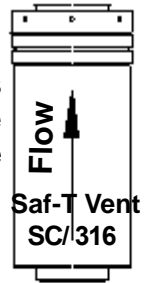

## Appliance Connection:

- Install the appliance adapter onto the appliance outlet, placing the end with the snap ring away from the appliance. Secure the adapter onto the outlet collar using the three self-tapping screws provided. Follow the SC/SC 316 joint assembly instructions.

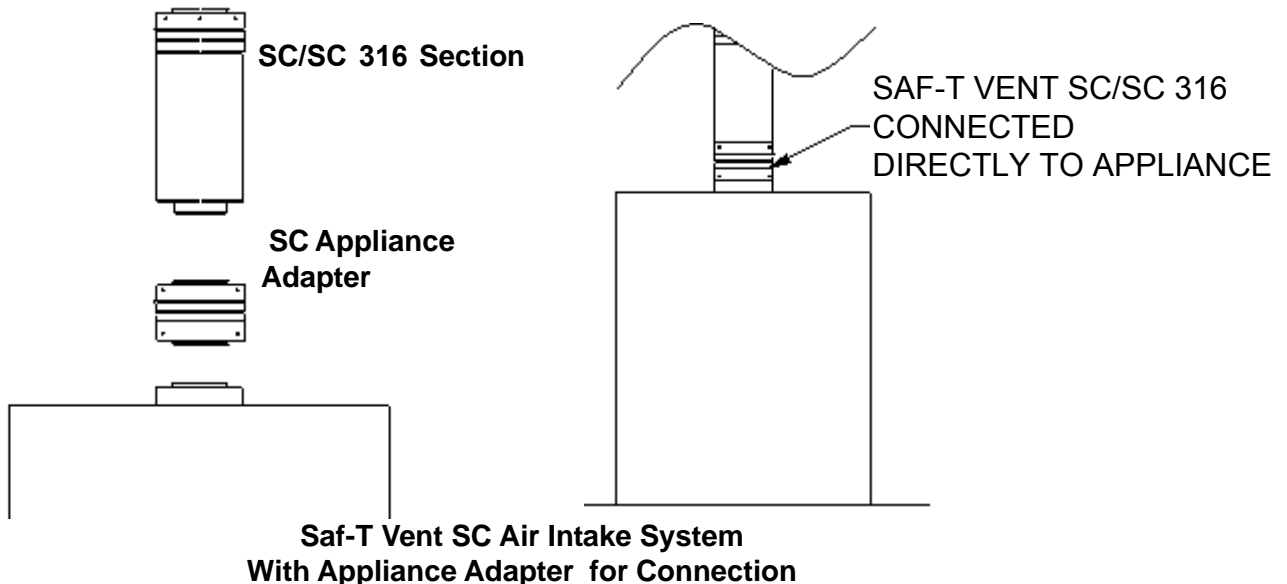

---

## Condensate Drains:

When An Internal Condensate Drain Is NOT Part of the Appliance:

- A Saf-T Vent SC/SC 316 In-Line Drain Section is strongly recommended. Install this drain fitting as close to the appliance flue collar as possible.
- A condensate drain is required for every 30 feet of horizontal vent and at/near the bottom of a vertical stack.
- Use the In-Line Drain Section for a straight horizontal or vertical run. When used horizontally, rotate the fitting so that the drain tube is as vertical as possible.
- A Condensate Drain Tube Kit is available to direct the condensate to an appropriate location, i.e. floor drain or vented sanitary sewer connection. A trap loop must be formed into the drain hose and must be a diameter that is at least four times the appliance's rated stack pressure in inches of water column or 3 inches, whichever is greater. Secure the loop with a cable tie. Prior to final assembly the trap loop must be 'primed' by pouring a small quantity of water into the drain hose. Inspect at least annually to verify the trap is 'primed'.
- Follow all local and national codes and regulations for the draining of acidic condensate.
- In cold climates do not install a condensate drain on the exterior of the building. Doing so may result in dangerous icy conditions on surfaces near the drain and may cause damage to the vent system and/or the building exterior. Heat-fab, Inc. will **NOT** be held liable for any injury or property damage due to formation of ice.

### Typical SC/SC 316 Connections and Drain Placements:

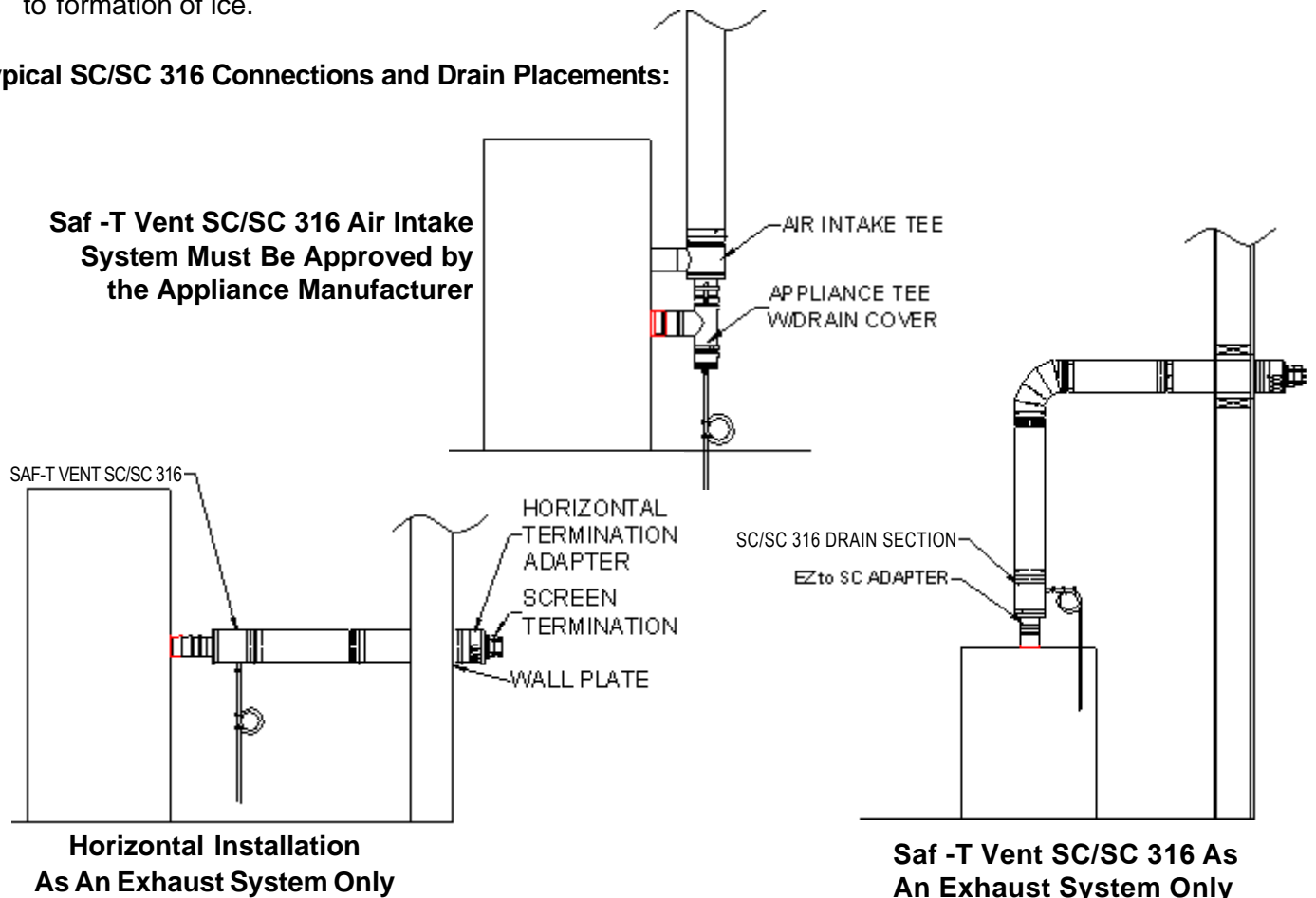

---

## Horizontal Supports:

Saf-T Vent SC/SC 316 must have supports for every six (6) feet of horizontal run and after every transition from vertical to horizontal. Support hangers by themselves do not maintain the necessary clearances to combustibles; be sure to consider clearances when planning the system.

The supports must be secured to solid material using at least #10 fasteners. Do not fasten supports to drywall sheathing without using hollow wall anchors. The conduit supports must maintain the 1/4" per foot pitch to avoid collection of condensate in the vent. Position the vent so that the welded seam is on the top.

**0" Clearance Support Clamp, (SC\_\_SUP):** Attach the bracket to the structure but do not tighten in place. Open the hose clamp and slip it under the support bracket. Position the clamp between the mounting screws and rotate the clamp so that the screw housing will be accessible after the vent is installed. Restart the threads on the hose clamp and securely tighten the mounting screws to the structure. This can also be installed vertically.

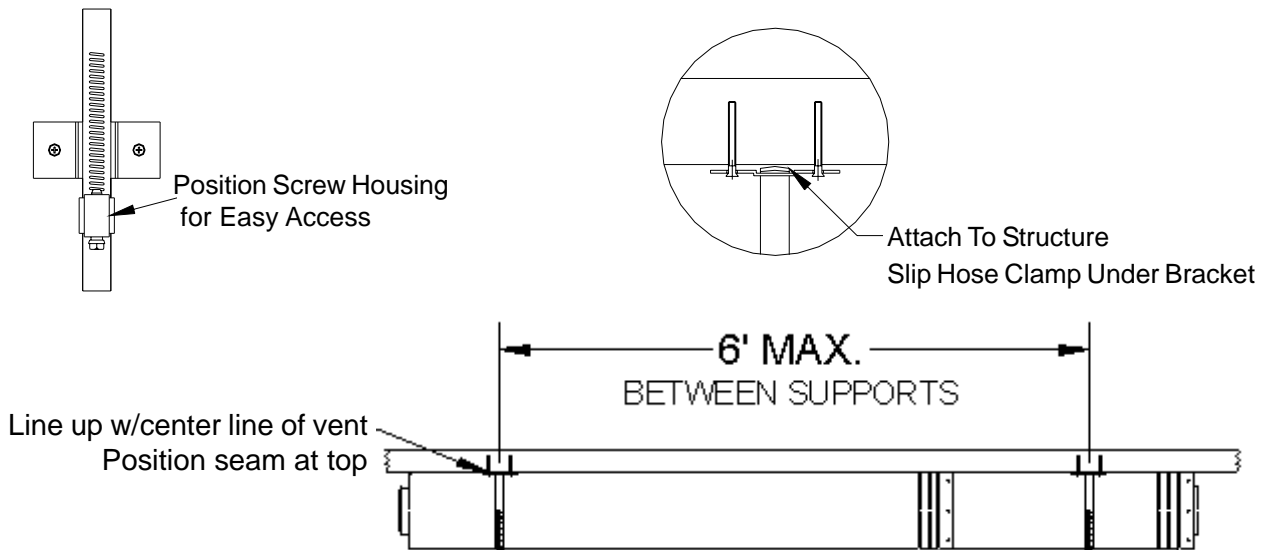

**1" Clearance Support Clamp, (SC\_\_SUP1):** Supports the vent at 1 inch clearance to the structure. Line up the support mounting brackets so that the mounting screws will follow the center line of the vent section. This can also be installed vertically.

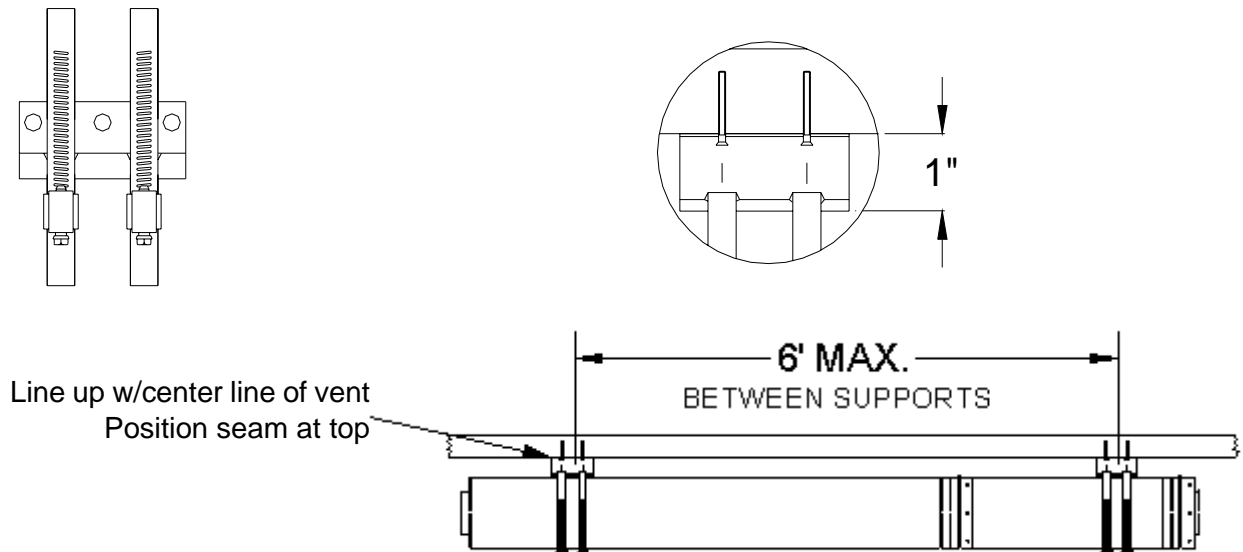

**Support Clamp, (4\_\_27SS):** Support clamps are sold in pairs and can be clamped around the vent and suspended from a rod or cable. They can be used singularly as a saddle clamp to rest the vent in and suspended from two rods or cables.

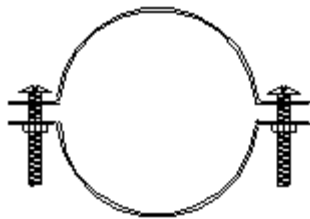

**Support Clamp**



**Support Legs Rotated Horizontally:** Support legs can be used on horizontal runs by rotating the clamp at the rivet connection. The legs can be cut to shorter lengths if necessary.

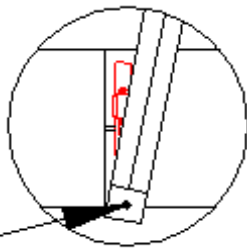

**Rotate Clamp**

**Support Legs**

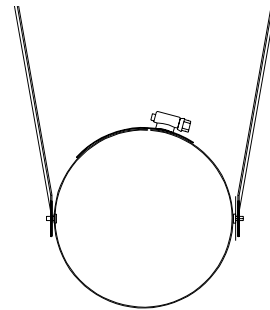

**Vertical Supports, (SC\_\_VSL):**

Vertical support legs can be used above or below a structure for support. To install, slide the support clamp over the end of the vent section, leaving the clamp loose. Position the support legs and install 2 screws through each leg into the structure. Tighten the clamp around vent pipe. The legs can be cut to shorter lengths if necessary and can rotate around the support clamp at the rivet connection. By rotating the clamp to a horizontal position the support legs can be used on horizontal runs.

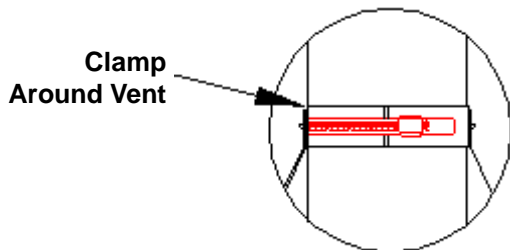

**Clamp Around Vent**

**Screw to Structure**

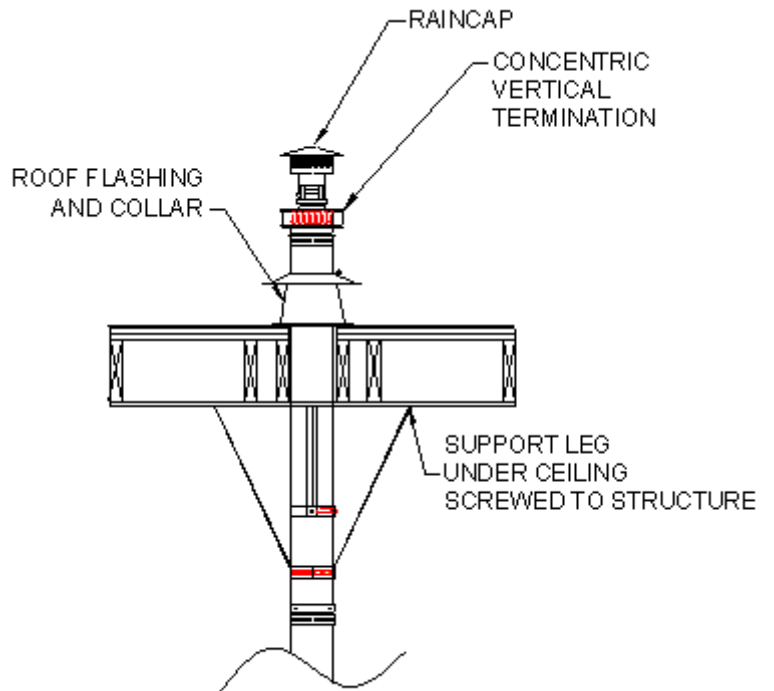
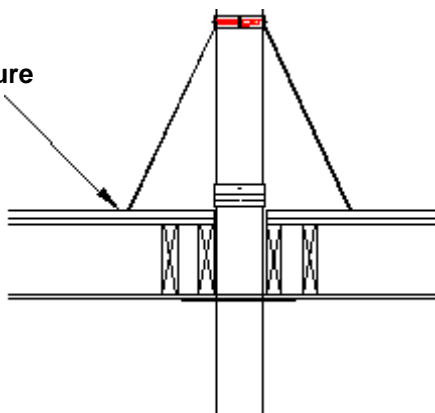

**Vertical Support Legs**

**Fire Stop/ Wall Thimble/ Support, (SC\_\_FS):**

- The Saf-T Vent SC Fire Stop can be used as a firestop, a wall thimble, or as a support plate.
- To use as a Wall Thimble prepare an opening according to the chart below. Remove any insulation from the opening, using additional framing if necessary. Attach the plate over the center of the opening using appropriate fasteners.

**Opening**

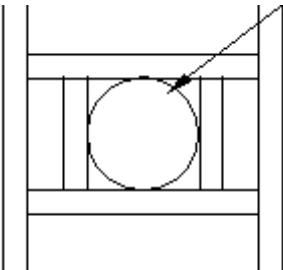

WALL OPENING FRAMING DIMENSIONS			
PART NUMBER	INNER VENT DIAM	COMBUS-TIBLE WALL	NONCOM-BUSTIBLE WALL
SC03FS	3"	7"	5.25"
SC04FS	4"	7"	7.25"

**Attach at Corners**

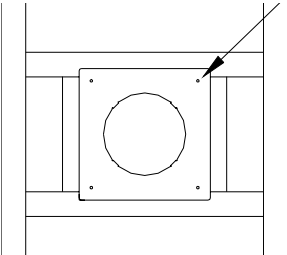

- Install the vent section through the thimble plate and secure the section to the thimble by screwing the self-tapping screws through the holes in the tabs on the plate and into the outer wall of the vent. Apply silicone sealant around the vent section where it passes through the plate and around the plate where it is attached to the structure.
- To use as a Firestop before passing through ceilings or enclosed chases, prepare a round or square opening 1/4" larger than the outer jacket ( 5 1/4" for 3" vent or 7 1/4" for 4" vent). Remove any insulation from the opening. Secure the firestop to the structure at the 4 corners. Install the vent section through the firestop and secure the section to the thimble by screwing the self-tapping screws through the holes in the tabs on plate and into outer wall of the vent. This method can also be used to support the vent section either vertically or horizontally.

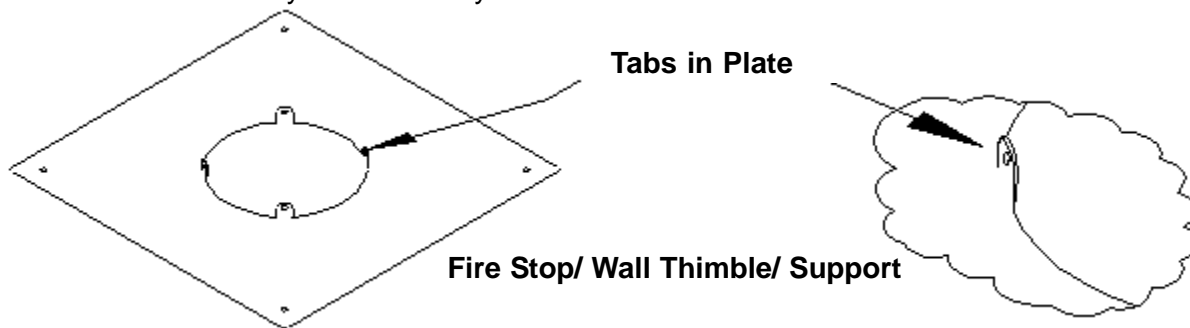

**Horizontal Termination Adapter, (SC\_\_HT):**

- Install the horizontal termination adapter, into the last vent section with the air vent openings facing downward. Secure the adapter to the vent section with the 3 self-tapping screws provided. Attach a Saf-T Vent termination to the end of the horizontal termination adapter.

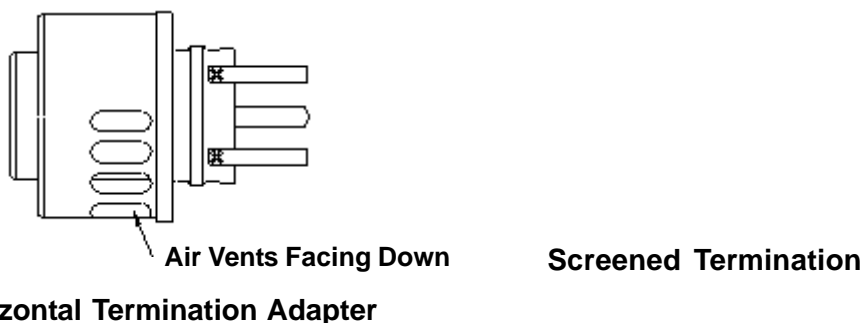

---

## Tall Cone Flashing:

### *Directly On Roof or Curb:*

Tall Cones are available for flat (SC\_\_TCF), 2/12 pitch - 6/12 pitch (SC\_\_TCFA), and 6/12 -12/12 pitch roofs (SC\_\_TCFB). Prepare a square or round opening at least 1/4" larger than the outer jacket (5 1/4" for 3" vent or 7 1/4" for 4" vent). Remove any insulation from the opening. Apply weather-stripping or outdoor caulk to the bottom of the cone plate and attach the plate to the roof using common construction methods. Flash over the cone plate and seal the fastener heads using normal roofing requirements. When the vent pipe is in place through the Tall Cone, attach a storm collar (sold separately) around the pipe. Apply high temperature silicone sealant around the pipe where it passes through the top of the storm collar. Continue to install vent sections as needed to meet the height requirements by code. **Seal weather exposed joints of the outer jacket with foil tape or an exterior grade silicone sealant.**

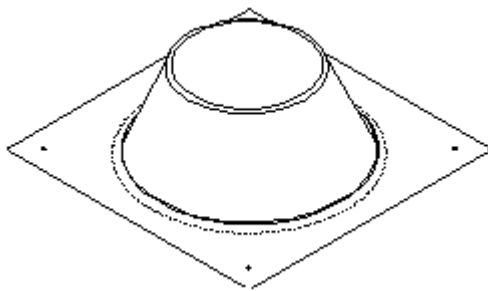

**Tall Cone Flashing**

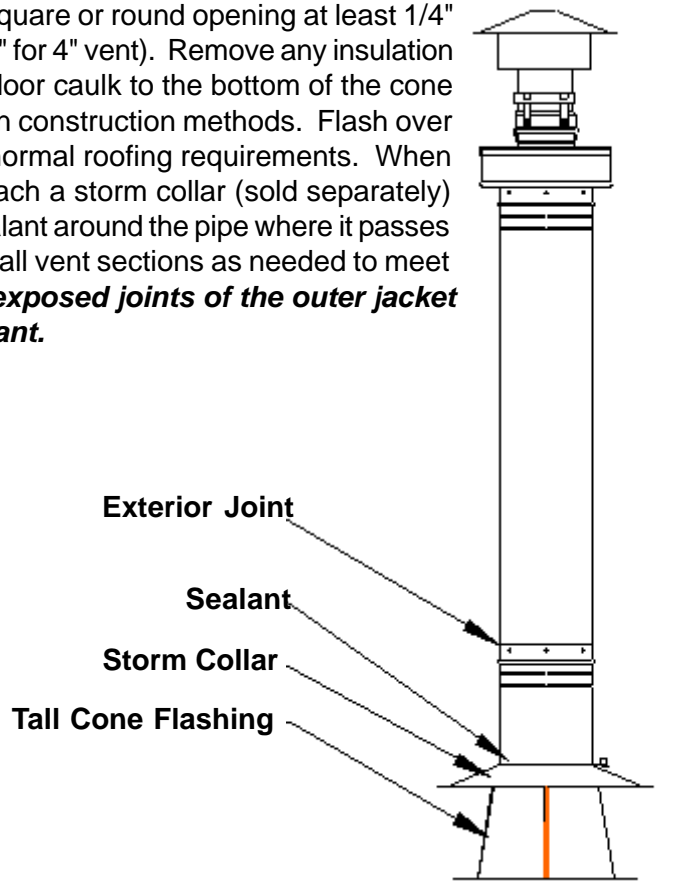

## Vertical Terminations, (SC\_\_VT):

Install the vertical termination adapter into the last vent section and secure with the 3 self-tapping screws provided. Attach a rain cap or other appropriate Saf-T Vent exhaust termination to the end of the vertical termination adapter. If the exhaust termination needs to be extended, a section of EZ Seal/EZ 316 vent can be connected directly to the vertical termination adapter. **Seal weather exposed joints of the outer jacket with foil tape or an exterior grade silicone sealant.** To allow for inspection of the system, do not seal the exhaust termination.

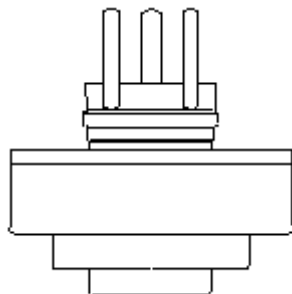

**Termination Adapter**

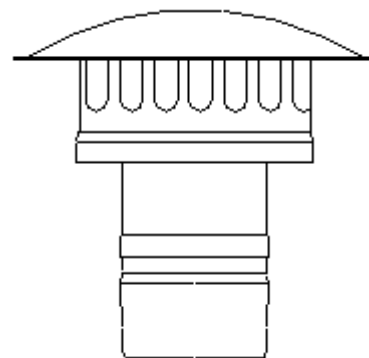

**SC Rain Cap  
Exhaust Termination**

---

## Maintenance Procedures:

- Normal operation of gas burning appliances does not result in deposits of combustible soot in venting systems. However, a poorly adjusted or malfunctioning appliance can deposit soot and other debris which can enter the vent system. As with all vents, the Saf-T Vent SC/SC 316 system should be inspected at least annually for the presence of deposits of soot or debris. Any such accumulation should be removed and the appliances adjusted to eliminate future accumulation.
- The system should also be inspected at least annually for signs of leakage of condensate or combustion by-products at all joints. If any leakage is found the connected appliances should be turned off and the leaks repaired.
- If the system incorporates a drain hose from either an in-line fitting or from a drain tee then the hose must be inspected periodically to assure that water remains in the trap loop. If a proper trap loop is not maintained exhaust from the connected appliances may accumulate in the building area.