

Installation and Maintenance Instructions

Saf-T Vent[®] Model EZ Seal/EZ 316 and Model GC/GC 316

Single Wall
Gas Vent Connector
Chimney Liner &
Special Gas Vent (USA) / Type BH Vent Class I/II (Canada)

For Venting Residential, Commercial & Industrial Appliances
Category I, II, III & IV Appliances

**Model EZ Seal/EZ 316 - 6"-16" Diameter Vent for use on Positive, Neutral
and Negative Pressures up to 9" W.C.**

**Model GC/GC 316 - 18"-32" Diameter Vent for use on Positive, Neutral and
Negative Pressures up to 15" W.C.**

Important: Do NOT install this product until you have read and fully understand these installation instructions. Failure to comply with these instructions may result in injury or damage to property. An improper installation will void any stated warranty.

- Follow these instructions exactly as written.
- Examine all components for possible shipping damage prior to installation.
- Proper joint assembly is essential for a safe installation. Check integrity of joints upon completion of assembly.
- This venting system must be supported in accordance with these instructions.
- Check for restricted vent movement through the walls, ceilings and roof penetrations. This venting system must be free to expand and contract.
- Do not mix Saf-T vent pipe with pipe from different manufacturers.

⚠ WARNING!!

Failure to follow the installation instructions could cause FIRE, CARBON MONOXIDE POISONING, OR DEATH. If you are unsure of installation requirements, please call the phone number listed on the instructions or visit the website shown.



Tested and Listed to
UL1738 & ULC S636
By Underwriters Laboratories, Inc.

heatfab[®]
5030 Corporate Exchange Blv
Grand Rapids, MI 49512
Call 800 772-0739
Fax 800 972-1421
www.heatfab.com

APPLICATION INFORMATION

Saf-T Vent Model EZ Seal/EZ 316 and Model GC/GC 316 Gas Vent Systems may be used to vent safety certified Category I, II, III, IV and Certain Direct Vent gas appliances with a flue gas temperature of not more than 550° F (288° C). When used as a masonry chimney liner, Saf-T Vent EZ Seal/EZ 316 (up to 10" diameter) can be used to vent condensing oil appliances and category I, II, III, IV gas fired appliances. The Saf-T Vent EZ Seal/EZ 316 system is for use with appliances which produce positive vent pressures of 9 inches of water column or less and Model GC/GC316 is for use with appliances which produce positive vent pressures of 15 inches of water column or less. Saf-T Vent Model EZ Seal, EZ 316, GC and GC 316 components are compatible and may be combined for installations. Because these types of appliances may produce vent gases under positive pressure and/or at or near their dew point, special installation considerations may be required.

Install in accordance with these instructions and those of the appliance manufacturer. Consult the appliance manufacturer's instructions for the maximum horizontal length of the vent connector as well as any restriction on total vent height, proper sizing of the vent, common venting considerations and procedures for connecting the vent to the appliance.

The installation must conform to applicable National, Regional, State and local codes. Contact the Authority Having Jurisdiction prior to beginning any work to obtain any required permits.

Pre-Installation Considerations:

Proper planning prior to installation is essential for maintaining proper clearances and for avoiding possible contact with concealed plumbing or electrical wiring inside walls, floors and ceilings. A continuous straight-line upward pitch of at least 1/4 inch (2 degrees) rise per foot on horizontal runs must be maintained in order to properly rid the system of the corrosive condensate. Be sure to plan a sufficient number of supports for the entire system to maintain the required straight-line pitch and to hold the system in place.

Reference *Combustion & Ventilation Air* on the last page for proper air supply guidelines

Personal Safety

Wear eye protection and heavy gloves throughout the installation. In addition, wear an approved dust and vapor respirator whenever in contact with building insulation. Proper and safe scaffolding and/or ladders should be used. Check overhead for antennas, power lines or other obstacles before erecting ladders or scaffolding and while working with conduit on any roof structure.

Tools Required for Installation

Common building tools including but not limited to a Tape Measure, Pliers, Screw Drivers, Saws and/or Snips, Drills, Drop Cloth(s); Ladder/Scaffold; Safety and Personal Protective Clothing.

Definitions:

AL 29-4C – A super ferritic stainless steel alloy designed by Allegheny Ludlum for extreme resistance to chloride ion pitting, crevice corrosion and stress corrosion cracking. Equivalent material made by other manufacturers may be identified by the UNS designator S44735.

316L – An austenitic chromium-nickel stainless steel containing molybdenum. Type 316L is an extra-low carbon version of Type 316 that minimizes harmful carbide precipitation due to welding. Type 316L is used in applications where immunity to carbide precipitation due to welding assures optimum corrosion resistance. 316L may be identified by the UNS designator S31603.

Category I Appliance - An appliance which operates with a non-positive vent static pressure and with a vent gas temperature that avoids excessive condensate production in the appliance.

Category II Appliance - An appliance which operates with a non-positive vent static pressure and with a vent gas temperature that may cause excessive condensate production in the appliance.

Category III Appliance - An appliance that operates with a positive vent static pressure and with a vent gas temperature that avoids excessive condensate production in the appliance.

Category IV Appliance - An appliance that operates with a positive vent static pressure and with a vent gas temperature that may cause excessive condensate production in the appliance.

Combustible Material - Any material made of or surfaced with wood, compressed paper, plant fibers, or other materials that are capable of being ignited or burned. Such material shall be considered combustible even though it is flame proofed, fire-retardant treated, or plastered. (Source: NFPA54/ ANSI Z223.1-2006.).

Clearance to Combustibles and Framing Requirements

Table 1 shows the required MINIMUM AIRSPACE CLEARANCE TO COMBUSTIBLES. EZ Seal/EZ 316 - 6"-16" and model GC/GC 316 are primarily intended for installation in fire resistive, non-combustible surroundings or installed unenclosed. This airspace clearance is required for safe operation of the vent. Failure to follow these clearances could overheat the building materials and could cause fire.

Pipe Size	Max Appliance Operating Temperature	Minimum Airspace Clearance to Combustibles		
		Vert & Horiz Unenclosed		Minimum Framing Dimension (Through a Wall or Roof)
6-12"	230°F*	0"*	0"*	0": Enough to allow pipe passage
14-32"	194°F*	0"*	0"*	0": Enough to allow pipe passage
6-10"	300°F	1"	1"	N/A (Gas Vent Connector Only)
6-12"	550°F	2"	2"	(ID + 5") X (ID + 5")
14"	550°F	3"	3"	(ID + 5") X (ID + 5")
16"	550°F	4"	4"	(ID + 5") X (ID + 5")
18"	550°F	4"	4"	(ID + 7") X (ID + 7")
20-22"	550°F	5"	5"	(ID + 7") X (ID + 7")
24-26"	550°F	6"	6"	(ID + 7") X (ID + 7")
28-32"	550°F	7"	7"	(ID + 7") X (ID + 7")

* Permitted to be fully enclosed with combustibles at 0" clearance per ULC-S636

Vertical (Floor, Ceiling and Roof) Penetrations

All vertical penetrations where the vent passes through a combustible floor, ceiling or roof, require a Fire Stop (p/n 5x18C1) or Roof Jack be installed. See Table 1 for proper framing dimension and refer to the Fire Stop or Roof Jack Section for proper installation. Non-combustible Floor, Ceiling & Roof Penetrations do not require a Fire Stop or Roof Jack.

Horizontal (Wall) Penetrations

Horizontal systems passing through a combustible wall require the use of a Wall Penetration, for relative temperatures with clearances. See Table 1 for proper framing dimensions and refer to Wall Penetration section for installation instructions. Non-combustible wall penetrations do not require a Wall Penetration.

TYPICAL INSTALLATIONS

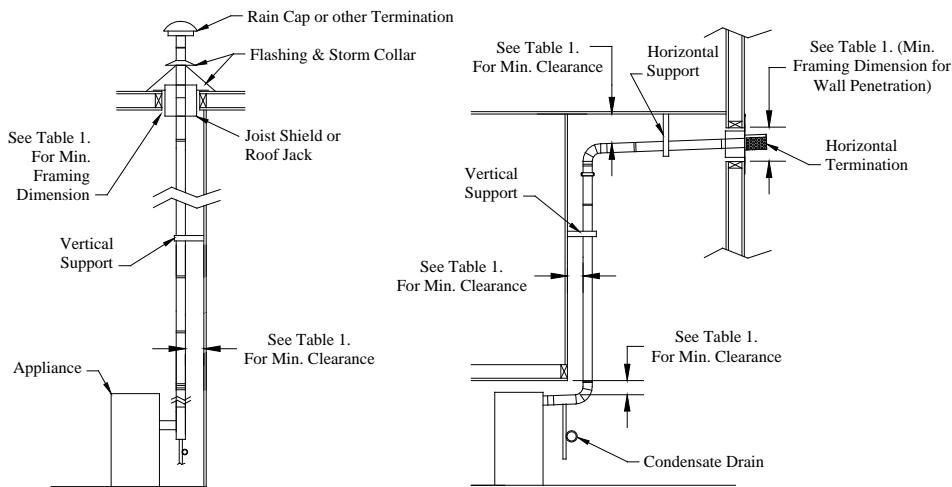

Fig 1. (Vertical Termination)

Fig 2. (Horizontal Termination)

In addition to the configurations shown in Figs. 1 & 2, this system may be installed in any combination of vertical and horizontal, unenclosed configurations as long as the minimum clearances are maintained per clearance Table 1 and the total length and number of fittings does not exceed the appliance manufacturers recommendations. This system may also be installed within an existing masonry chimney.

Notes:

1. Unenclosed systems require at least one side open (combustible material on maximum of 3 sides).
2. Reduced clearances may be attained by using noncombustible enclosures.
3. Systems fully enclosed by combustible material are NOT permitted.
4. Do not place insulation in any required clearance spaces surrounding the vent system unless these instructions suggest otherwise and the insulation is specified or supplied.
5. Noncombustible enclosures require 0" air space.

VENT ROUTING LIMITATIONS - MAXIMUM EQUIVALENT LENGTHS

In order to insure the vent system is not overly restrictive to flow, refer to the maximum length of vent specified by the appliance manufacturer. In order to account for turns in the system (which cause additional resistance to flow) most manufacturers recommend using an "Equivalent Length" method of determining the limitations. Via such method, elbows and tees are assigned an "equivalent length" (in feet). If the sum of straight length segments and additional "equivalent lengths" (due to turns) exceeds the limit specified by the manufacturer, the routing is not permitted. See appliance manufacturer's instructions for additional information.

If the appliance manufacturer's instructions do not list equivalent lengths for standard fittings, use Table 2 to determine the Equivalent Length of the vent fittings.

Equivalent Length Table	
Fitting	Equivalent Length
Straight Length	1' per 1'
Boot Tee	10'
90 Degree Elbow	10'
70 Degree Elbow	8'
45 Degree Elbow	5'
30 Degree Elbow	4'
15 Degree Elbow	3'

Table 2

GENERAL INSTALLATION REQUIREMENTS

1. In instances where the appliance manufacturer's instructions conflict with requirements in this document, the appliance manufacturer's instructions take precedence.
2. Failure to conform to any of these requirements may violate local, state or national codes as well as create conditions which may cause catastrophic property damage and/or personal injury.
3. The horizontal vent connector must slope **upward** toward the termination at least 1/4 inch per foot and be installed so that all condensate runs back toward the appliance or inline drain and is not retained in any part of the venting system.
4. If called for by the appliance manufacturer's instructions, a drain fitting must be located as close as possible to the appliance flue outlet. Additional drains are required for each 30' of vent. If a drain fitting is not supplied with the appliance, install a Saf-T Vent in-line drain or a tee with a drain tee cover. Properly dispose of collected condensate.
5. Multiple Category III or IV appliances may not be interconnected to any part of the venting system unless the appliance manufacturer has specifically approved the engineering of the vent system. A Category III or IV appliance may not be interconnected to any part of a vent system used with a natural draft or draft hood appliance, except when a listed mechanical draft system is installed.
6. For venting systems that extend through any zone above that on which the connected appliance is located (except for one and two family dwellings), codes require that the vent system be enclosed with an enclosure having a fire resistance rating equal to or greater than that of the floor or roof assemblies through which it passes. In one and two family residential construction the system must be enclosed whenever passing through occupied spaces. The enclosure should be fabricated to allow periodic inspection of the vent.
7. Whenever gas-burning equipment is installed in the same space where halogenated substances may exist (refrigerants, solvents, bleaches, salts, etc.), clean outside air must be utilized for combustion.
8. When passing 5' or more of vent through an unheated area (such as attics, crawl spaces, building exteriors or above roof lines), it is recommended that the system be converted to double wall CI Plus/CI 316 to prevent condensation and freezing.
9. The vent system shall not be routed into, through or within any other actively used vent or chimney.
10. Another appliance may not vent into the flue space outside the Saf-T Vent conduit. However, if there is sufficient space and all manufacturer's instructions and codes are followed, a separate chimney liner may be installed within the chimney to vent another appliance.

HORIZONTAL INSTALLATION REQUIREMENTS

1. If the termination is through a combustible wall, the system must include Wall Penetration and a Saf-T Vent termination as required by the appliance manufacturer.

2. The horizontal termination shall be located not less than 12 inches above grade or anticipated snow line (remember to consider snow and ice falling from overhead objects), and not less than 7 feet above grade when located adjacent to a public walkway. It shall also terminate a minimum of 4 feet below, 4 feet horizontally from, or 1 foot above any door, window, fresh air intake, utility meter or regulator unless the appliance is Listed differently. The termination must be a minimum of 6 feet from the combustion air intake of any other appliance. Proper judgment may require greater distances depending on the size of the equipment installed or site conditions. Consult with the local Authority Having Jurisdiction.
3. The termination should be away from trees, shrubs, or decorative items as flue gases could cause damage.
4. The total equivalent horizontal distance of the vent system from the appliance flue collar to the outside of the termination shall not be less than 14 inches.
5. A minimum of one (1) horizontal support is required for every 6 feet of run.

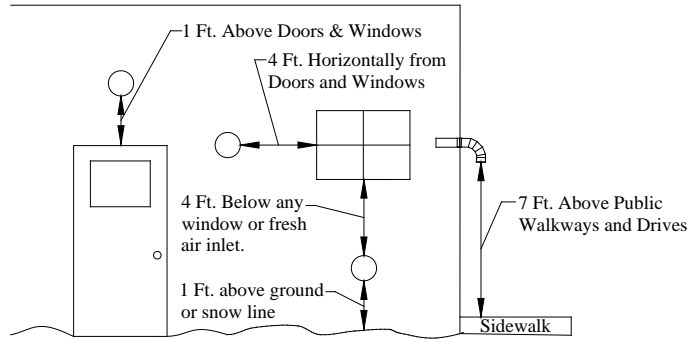
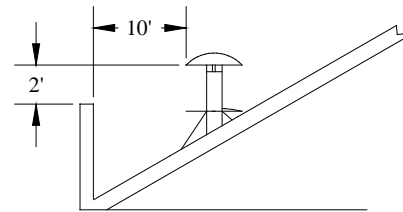

Fig 3. (Horizontal Installation Requirements)

VERTICAL INSTALLATION REQUIREMENTS

1. The vent system must terminate at least 3 feet above the roof line and at least 2 feet higher than any portion of the building within 10 feet.
2. When terminated at a height of more than 6 feet above the roof, the vent must be supported by a Saf-T Vent Guy Section. Refer to the Guy Support section of these installation instructions.
3. The vent system must terminate with one of the Saf-T Vent Terminations; except when a Termination or approved mechanical vent device is specified or provided by the appliance manufacture.
4. The total continuous distance of the vent system from the appliance flue collar to the termination shall not exceed that specified in the appliance manufacturer's installation instructions. When venting natural draft appliances the termination must be at least 5 feet above the topmost draft hood. Otherwise a Listed mechanical draft inducing device is required.
5. Vertical supports are required after every transition to vertical. Vertical supports are also required above every offset elbow. See Table 3 for vertical support requirements.



(2 Ft. Above Structures within 10 Ft.)

Fig 4. (Vertical Installation Requirements)

JOINT SEALING AND CONNECTION METHOD

Model EZ Seal/EZ 316 (Diameters 6" thru 16") is joined using the Ring & Tab Method. EZ Seal/EZ 316 is also manufactured with a factory installed seal on the inside of the female (outlet) end making the use of any additional sealant unnecessary.

To Connect:

Note: It is required to apply gasket lubricant (p/n 7001SIL-5, sold separately) to the factory installed silicone gasket when assembling the pipe. Apply lubricant directly to the gasket on the inside female pipe end, both edges of gasket.

1. Connect parts using the Ring and Tab Connection Method. See Fig 5A.
 - a. To connect, slide the lock ring away from the end to allow clearance for the tabs extending from the female end.
 - b. Engage the two sections making sure the tabs stay to the outside of the vent.

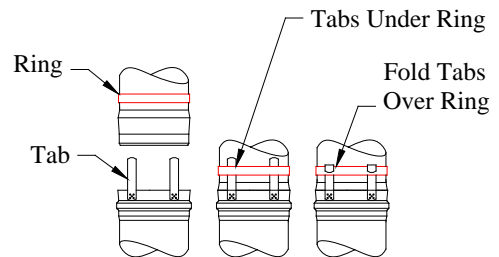

Fig 5A. (Ring and Tab Joint)

- c. After the sections are fully engaged, slide the lock ring down over the tabs, making sure all tabs are contained within the lock ring.
- d. Bend the tabs back over the lock ring to complete the joint. Note: Some termination parts have a hose clamp in place of the lock ring. In such cases, the hose clamp is tightened down over the tabs. The tabs need not be bent over the clamp.

Model GC/GC 316 (Diameters 18" thru 32") is joined using the Locking Strap method. Model GC/GC 316 requires sealant to be applied at each joint during the assembly process.

To Connect:

1. Remove the Locking Strap from the Vent (See Fig.5B)
2. Wipe/clean the outlet and the inlet ends of the GC/GC316 pipe with alcohol wipes.
3. At $\frac{3}{4}$ " inside the outlet end, apply a $\frac{1}{4}$ " thick, continuous, straight-line bead of high temperature sealant to the inside circumference. Do not use a zig-zag pattern when applying sealant.
4. Smooth down the bead with a flat instrument or moistened finger (See Fig. 5B).
5. Insert the male (outlet) end into the female (inlet) end, and align the Locking Tabs on the two parts.
6. Wrap the Locking Strap around the joint so that the tabs extruding from the vent align and engage into the slots in the Locking Strap. NOTE: The Tabs on the male end of elbows and tees are permitted to rotate so that the vent can be aligned to the desired direction.
7. Install Bolt and Nut through the end tabs of the Locking Strap and tighten strap using a 7/16" nut driver or socket. CAUTION: DO NOT over tighten the clap as it may cause the vent to collapse (See Fig 5B).

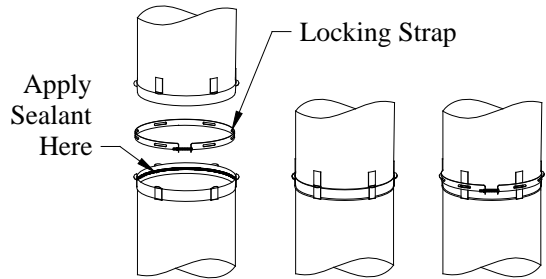

Fig 5B. (Locking Strap Joint)

Condensate Drains:

When An Internal Condensate Drain Is NOT Part of the Appliance:

- A Saf-T Vent In-Line Drain Section, Tee or Boot Tee with a separate Tee Cover Drain is strongly recommended. Install this drain fitting as close to the appliance flue collar as possible (See Fig. 6A).
- Use the Boot Tee to transition from horizontal to vertical and attach the Drain Tee Cover to the appropriate leg of the tee (See Fig 6A).
- A condensate drain is required for every 30 feet of horizontal vent and at/near the bottom of a vertical stack.
- Use the In-Line Drain Section for a straight horizontal run. Rotate the fitting so that the drain tube points downward and is as vertical as possible (See Fig. 6B).
- A Condensate Drain Tube Kit is available to drain the condensate to an appropriate location (i.e. floor drain or vented sanitary sewer connection). A trap loop must be formed into the drain hose and must be a diameter that is at least four times the appliance's rated stack pressure in inches of water column or 3 inches, whichever is greater. Secure the loop with a cable tie. Prior to final assembly the trap loop must be 'primed' by pouring a small quantity of water into the drain hose.
- Follow all local and national codes and regulations for the draining of acidic condensate.
- In cold climates do not install a condensate drain on the exterior of the building. Doing so may result in dangerous icy conditions on surfaces near the drain and may cause damage to the vent system and/ or the building exterior. We will **NOT** be held liable for any injury or property damage due to formation of ice.

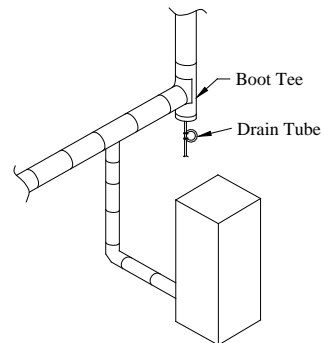

Fig 6A. (Boot Tee w/ Drain Cover & Tube)

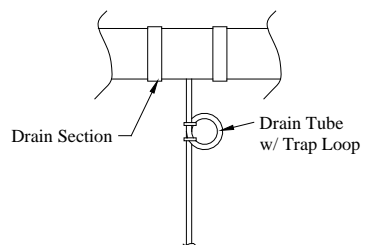

Fig 6B. (In-Line Drain Section and Drain Tube)

Adjustable Length

The Adjustable Length Section serves as a variable length between other components when specific lengths cannot be utilized and eliminates the need to cut parts to length. For proper installation, refer to instructions packaged with the Adjustable Length (See Fig. 7).



Fig 7. (Adjustable Length)

Customized Lengths— Cutting Standard Lengths

The Saf-T Vent EZ Seal/EZ 316 system (6"-16") is designed so that in most cases standard lengths will not need to be cut. There may arise, however, an occasional situation where standard lengths and adjustable length slip connectors are not adequate. In such cases, a standard length of Saf-T Vent may be field cut.

To custom cut a standard length part:

1. Measure the length of vent needed (Dim A) and add 3 inches to the result (See Fig. 8).
2. Measuring from the female end (end with the tabs) measure out the distance $A + 3"$ and mark it on the pipe.
3. Cut the pipe with an abrasive cutoff, plasma, or compound snips.

To help get a square cut, create a straightedge by wrapping masking tape around the waste side of the cut point. If using snips, start the cut at the male end and follow a spiral path around the pipe until the cutoff mark is reached.

4. File off any burrs that develop in the cutting process prior to assembling. If the cutting process distorts the roundness of the pipe carefully use your thumbs to re-round the end.
5. Apply high-temperature silicone sealant to the field-cut joint.
6. Assemble the joint using the procedures above.
7. A hose clamp must be used to retain the tabs.

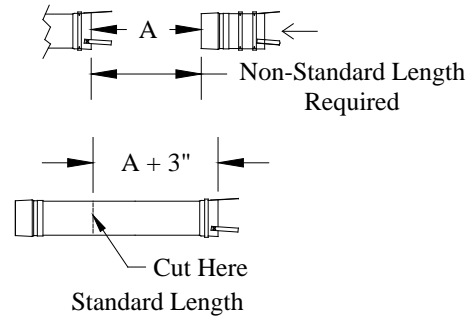

Fig 8. (Cutting Standard Lengths)

Spacing Between Supports		
Diameters	Vertical Spacing	Horizontal Spacing
6" to 12"	20'	Every six (6) feet and after every transition from vertical to horizontal.
14" to 18"	12'	
20" to 24"	10'	
26" to 32"	6'	

Table 3. (Vertical and Horizontal Support Requirements)

Vertical and Horizontal Support

For proper installation, Vertical and/or Horizontal supports must be installed to support the Saf-T Vent. Refer to **Table 3** for minimum spacing distances and the corresponding section for instructions for installing the support. Note: For all support options, ensure all minimum clearance to combustibles are maintained. Never drill or screw through the Saf-T Vent system.

Guy Support Section

The Guy Support is a short section of vent pipe with brackets protruding from it. These brackets provide a means for attaching a guy line, threaded rod or similar metal bracing to provide support to the vent system.

To Install: Connect Guy Section to the vent using standard joint connection method. Attach guy wires or metal bracing to the brackets provided on the Guy Section. Anchor guy wires or bracing to the building infrastructure capable of supporting the load of the vent (See Fig. 9).

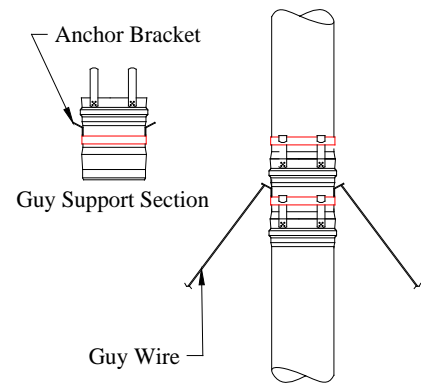

Fig 9. (Guy Support Assembly) (Model EZ Seal Shown)

Fire Stop

Wherever the vent passes through a ceiling or floor a Fire Stop (5x18CI) must be installed. To Install: Establish the correct framing dimension (See Table 1) and nail the Fire Stop to the joist (Fig 10a). Route the vent through the Fire Stop plate.

Caution about insulation in attics – Note: The Fire Stop should be located on the top of the joist to prevent insulation from falling into the joist. **Keep all attic insulation the proper minimum clearance from pipe** by installing an enclosure or similar around the pipe.

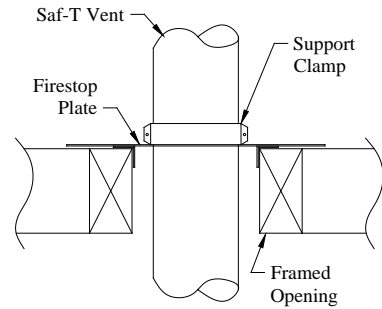

Fig 10a. (Fire Stop)

Support Clamps

Support Clamps may be suspended from rods or cables and used as a saddle to rest the vent in or they may be used in pairs to clamp around the vent and suspended from a single rod, or cable (See Fig. 10b).

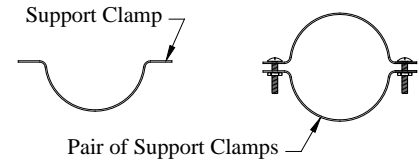

Fig 10b. (Fire Stop)

EZ Seal/EZ 316 Horizontal Clearance Support Clamp

The Horizontal Clearance Support Clamp (Sizes 3"-10") provides horizontal support for the vent and establishes a specified amount of clearance to combustible materials. To install: Secure the mounting plate to the wall by installing fasteners through the pilot holes in the mounting plate, and into the wall. Install a pair of Support Clamps around the vent, and secure the Support Clamp to the Horizontal support by installing a bolt through the mounting tabs on the Support Clamps and through the pilot hole in the 2" Horizontal Support (See Fig. 11).

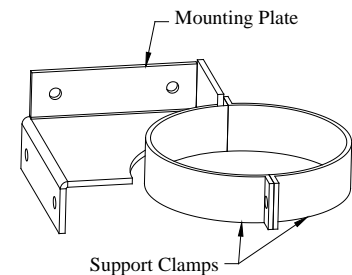

Fig 11. (2" Horizontal Clearance Support)

EZ Seal/EZ 316 Vertical Clearance Support Clamp

The Vertical Clearance Support Clamp (Sizes 5"-10") provides vertical support for the vent and establishes a specified amount of clearance to combustible materials. To install: Secure the mounting plate to the wall by installing fasteners through the pilot holes in the mounting plate, and into the wall. Route the vent through the Support Clamp and secure by tightening the Worm Gear (See Fig. 12).

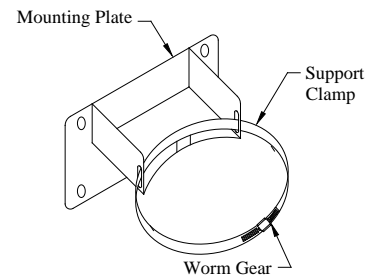

Fig 12. (2" Vertical Clearance Support)

Wall Penetration Assembly

A Wall Penetration Assembly is required when passing through a combustible wall.

To Install:

1. Prepare an opening in the wall where the Penetration will be installed. Refer to Table 1 for proper framing dimensions. The opening may be round or square as long as the minimum framing dimension is established. Additional framing may need to be added to the wall section to provide adequate support for the Wall Penetration Assembly.
2. From the outside, position the Wall Penetration into the hole (See Fig. 13).
3. Use fasteners to secure the Wall Penetration to the wall.
4. Proceed with installing the Saf-T Vent sections routing the vent through the Wall Penetration. The Vent must protrude at least 2 inches beyond the Wall Penetration and must have the required $\frac{1}{4}$ inch per foot pitch towards the appliance.
5. Install the End Collar on the section of vent that passes through the Penetration and position the End Collar so that it is in contact with the outlet end of the Wall Penetration and closes off the gap between the Wall Penetration and the Vent.
6. Secure End Collar by tightening the worm gear.

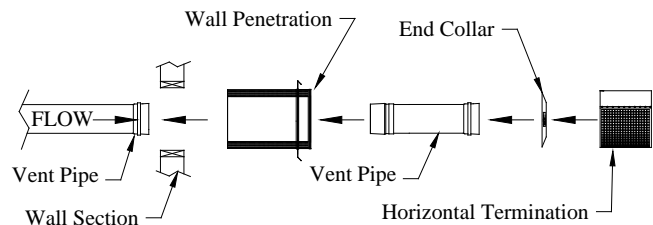

Fig 13. (Wall Penetration)

- Using Silicone Sealant, seal any gaps between the wall, the Wall Penetration, the End Collar and Saf-T Vent.

Wall Penetration & Horizontal Termination

The Wall Penetration & Horizontal Termination is the standard Wall Penetration Assembly that includes a Horizontal Termination. To install:

- Follow Steps 1-7 in the Wall Penetration Assembly Section.
- Align the Termination with the Wall Penetration so that the solid portion of the screen is rotated to the top.
- Secure the Termination to the Penetration with screws.
- The Termination may be easily removed for inspection of the venting system (See Fig 14).

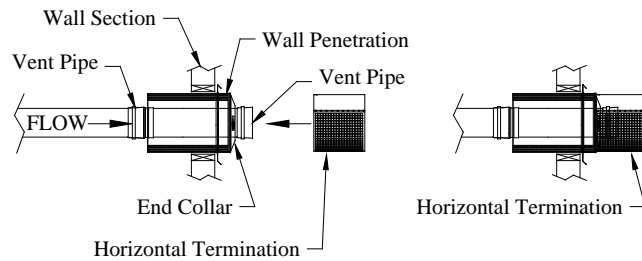

Fig 14. (Wall Penetration & Horizontal Termination)

Screen Terminations

Screen Terminations are used to terminate a horizontal vent system. There are several different Screen Termination styles available. These include the Mitered Termination Screen, an Elbow Termination with Screen and a Standard Screen Termination. All Screen Terminations are installed by using either the standard Ring & Tab Connection method or the Locking Strap Joint Connection method. All Screen Terminations must terminate a minimum of 6" from the wall (See Fig. 15).

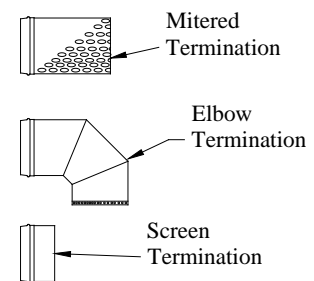

Fig 15. (Horizontal Screen Terminations)

Roof Jack

The Roof Jack provides for vertical penetrations through non-combustible ceiling or roof structures and also provides support for the vent system. For installation instructions refer to instructions packaged with the Roof Jack.

Tall Cone Flashing

The Tall Cone Flashing is for vertical terminations through a flat roof. Note: For combustible roofs a Joist Shield must be installed prior to installing the Flashing (See Fig. 17A).

To Install directly on Flat Roof:

- Prepare a round or square opening in the roof. See Table 1 for Clearance & Framing dimensions.
- Apply weather-stripping or outdoor caulk to the bottom of the cone plate.
- Attach the cone to the roof using common construction methods.
- Flash over the cone plate and seal the fastener heads using normal roofing requirements.
- Install Vent pipe through the Tall Cone. Refer to corresponding section for instructions on installing the Storm Collar and Rain Cap (See Fig. 17A).

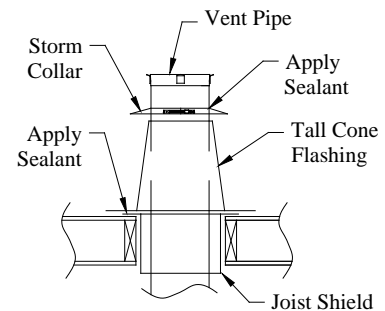

Fig 17A. (Tall Cone Flashing Directly on Flat Roof)

To Install on Roof Curb:

- Prepare roof curb using standard construction methods. See Table 1 for Clearance & Framing dimensions.
- Place the Cone on top of the curb and mark the outline of the curb on the bottom of the cone plate.
- Use snips to notch out the corners of the plate to match the outline of the curb.
- Apply weather-stripping or outdoor caulk to the bottom of the cone plate.

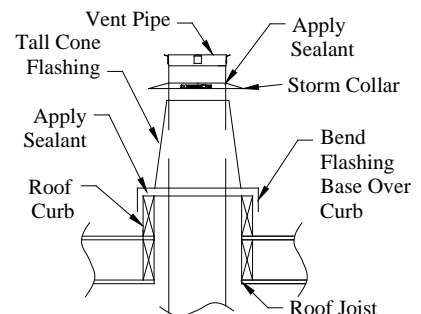

Fig 17B. (Tall Cone Flashing on Roof Curb)

5. Install Cone on top of curb and bend down the extra material with duckbill pliers to create a cap which fits over the curb.
6. Attach the cone to the roof using common construction methods.
7. Install Vent pipe through the Tall Cone. Refer to corresponding section for instructions on installing the Storm Collar and Rain Cap (See Fig. 17B).

Pitched Roof Flashing

The Pitched Roof Flashing is for vertical terminations through a non-combustible pitched roof. Note: For combustible roofs model CI-Plus flashing and Vent pipe should be used, refer to CI-Plus installation instructions for details.

To Install:

1. Prepare a round or square opening in the roof. See Table 1 for Clearance & Framing dimensions.
2. Apply weather-stripping or outdoor caulk to the bottom of the cone plate.
3. Attach the cone to the roof using common construction methods.
4. Flash over the cone plate and seal the fastener heads using normal roofing requirements.
5. Install Vent pipe through the Tall Cone. Refer to corresponding section for instructions on installing the Storm Collar and Rain Cap (See Fig. 18).

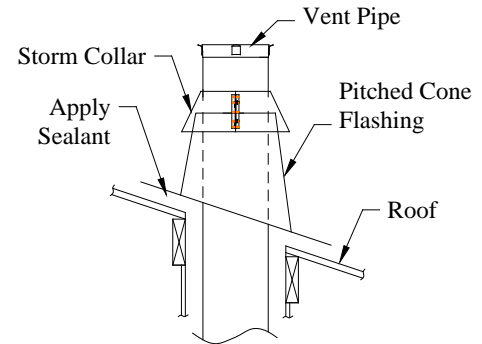

Fig 18. (Pitched Cone Flashing)

Storm Collar

The Storm Collar is designed to shed rain away from the flashing opening.

To install:

1. Place the Storm Collar over the last segment of vent and slide it down to where it is 2" above the outlet of the flashing. This 2" air space will release any buildup of heat from inside the cone.
2. Depending on the type of storm collar you have, tighten the worm gear or the bolts on the tab to secure the Storm Collar to the vent. Apply silicone sealant over the joint between the vent pipe and the Storm Collar (see Figs. 17A, 17B & 18).

Rain Cap

The Rain Cap terminates the vertical vent system and prevents rain from entering the vent. The Rain Cap includes a Storm Collar that is used to attach the rain cap to the vent system.

To Install:

1. Refer to Vertical Termination Requirements section for guidelines for locating the Rain Cap.
2. Depending on the type of Storm Collar you have, loosen either the worm gear or the bolts on the Storm Collar and slide the collar down over the pipe (See Fig. 19).
3. Install the Rain Cap onto the last vent pipe segment. Note: To allow removal of the Rain Cap for inspection Do NOT Seal joint with sealant.
4. Raise the Storm Collar up so that it is directly on the Locking Strap or Ring and Tab Joint and tighten Worm Gear or Bolts to secure Rain Cap to the Vent.

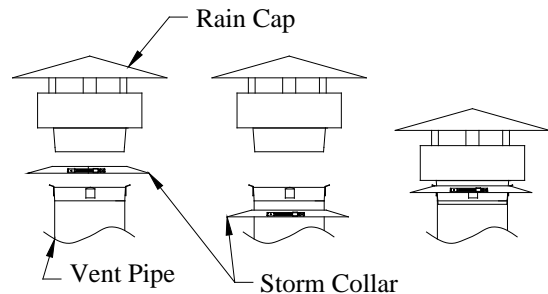

Fig 19. (Rain Cap)

Appliance Connectors

Connect the Saf-T Vent system to the appliance flue collar as directed in the appliance manufacturer's instructions. If the appliance flue collar is not designed for direct connection to the Saf-T Vent system, a special appliance adapter may be required. See Heat-Fab appliance adapter chart, the appliance manufacturer's instructions or contact Heat-fab for recommended adapters.

Notes:

Combustion & Ventilation Air:

In order for appliances and their vent / chimney systems to operate properly they require a plentiful supply of clean combustion and ventilation air. Requirements for such combustion and ventilation air are found in the installation and maintenance instructions accompanying the appliance as well as in vent manufacturer's literature and various mechanical codes. Seek and follow guidelines provided there when installing an appliance / vent system.

In addition to a plentiful source, it is very important for the combustion air to be free of certain chemical contaminants that can be very corrosive in nature to the appliance and / or venting system during and as a result of the combustion process.

In some cases, the use of indoor air is acceptable with the exceptions stated below. However, wherever possible, it is best to take combustion air directly from the outside, unless outdoor air has contaminant vapors nearby as listed below.

The following common list of substances need to be avoided in all instances since vapors associated with them – if mixed with the combustion air – can be extremely corrosive to the appliance and / or venting system. *Please note this list is not exclusive as to substance or effect and may be supplemented at any time.

- | | |
|---|---|
| a. Permanent wave solutions | h. Cleaning solvents (i.e. perchloroethylene) |
| b. Chlorinated waxes and cleaners etc. | i. Printing inks, paint removers, varnishes, |
| c. Chlorine based swimming pool chemicals | j. Hydrochloric acid |
| d. Water softening chemicals | k. Cements and glues |
| e. De-icing salts or chemicals softeners | l. Laundry room detergents, fabric |
| f. Carbon tetrachloride | m. Masonry acid washing materials |
| g. Halogen type refrigerants | |

Corrosion of the vent / chimney caused by the use of contaminated combustion air voids the warranty on these products.

Flue gas condensate with PH levels below 2.5 may also void the warranty. PH levels should be monitored regularly and if below 2.5, should be addressed with the boiler OEM on methods to raise it.

Maintenance Procedures:

- Normal operation of gas burning appliances does not result in deposits of combustible soot in venting systems. However, a poorly adjusted or malfunctioning appliance can deposit soot and other debris which can enter the vent system. As with all vents, the Saf-T Vent system should be inspected at least annually for the presence of deposits of soot or debris. Any such accumulation should be removed and the appliances adjusted to eliminate future accumulation.
- At regular periods the system should also be inspected for signs of leakage of condensate or combustion by-products at all joints. If any leakage is found the connected appliances should be turned off and the leaks repaired.
- If the system incorporates a drain hose from either an in-line fitting or from a drain tee then the hose must be inspected periodically to assure that water remains in the trap loop. If a proper trap loop is not maintained exhaust from the connected appliances may accumulate in the building area.